



INSTALLATION INSTRUCTIONS

MAINTAINED AND NON-MAINTAINED VALVE REGULATED LEAD ACID UNITS FOR LOW VOLTAGE
TUNGSTEN/TUNGSTEN HALOGEN LAMPS

CATALOGUE NUMBERS: LV1250/M3, LV1250/M3/EXT & LV1250/NM3

GENERAL DESCRIPTION

The unit comprises a lead acid battery charger with a red LED charging indicator, an automatic changeover device, deep discharge protection circuitry, an optional integral transformer for providing power to the lamp whilst the normal supply is healthy, and a combination of Valve Regulated Lead Acid batteries to provide 3 hour emergency duration of the specified lamp. The method of connection is via an option of 20mm knockouts located at the top of the unit into terminal blocks.

OPERATION

When the un-switched mains supply is connected to the unit, and the battery has been connected the indicator will light showing that the batteries are charging. A charge period of 24 hours should be allowed before testing the unit for its rated duration. If it does not achieve well over its rated duration period, the charge cycle should be repeated. It should be noted that simply connecting the battery to the module would not allow the lamp to light.

IMPORTANT NOTE WHEN USING DIMMABLE ELECTRONIC TRANSFORMERS!!!

If dimmable electronic transformers have been supplied, it should be noted that they are only suitable for 'hard fired' or 'zero crossing' type dimming systems.

FUSES

Two or three user serviceable fuses are located within the unit, depending on model. A 'T' rated 2A 20mm fuse is used in the fused terminal blocks in the un-switched & switched supplies (LV1250/M3 only). A 6.3A HBC 'F' rated 20mm fuse is used in the lamp output terminal.

DIMENSIONS

330mm length x 230mm width x 125mm height. Weight: 10Kg with batteries.

BATTERY INSTALLATION

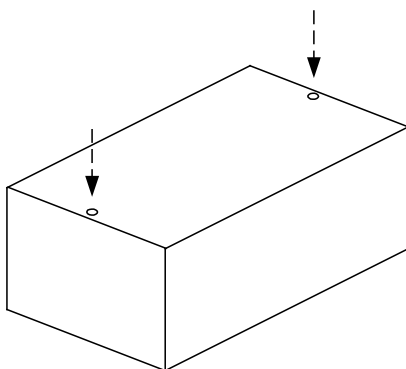

1) Remove 2 screws retaining lid then remove cover

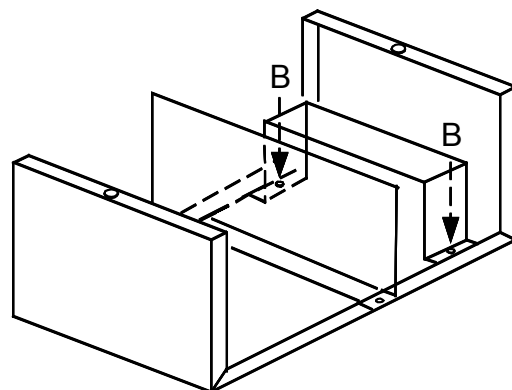

2) Remove 2 nuts B, remove battery retaining strap.

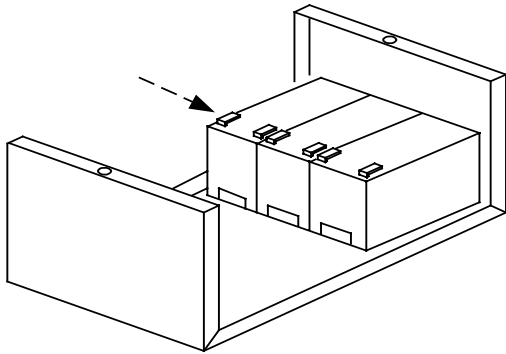

3) Insert batteries in space provided. Note orientation of battery by position of tags.

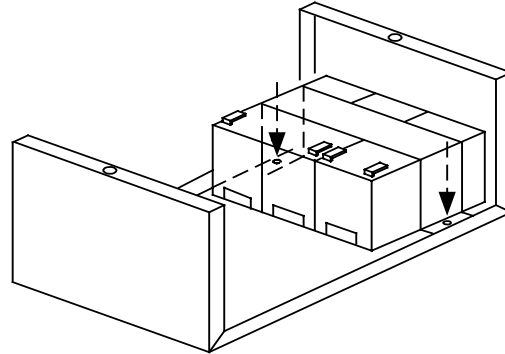

4) Locate battery retaining strap over bolts or studs. Fix with 2 x M4 nuts (B) provided. (Central mounting plate not shown for clarity)

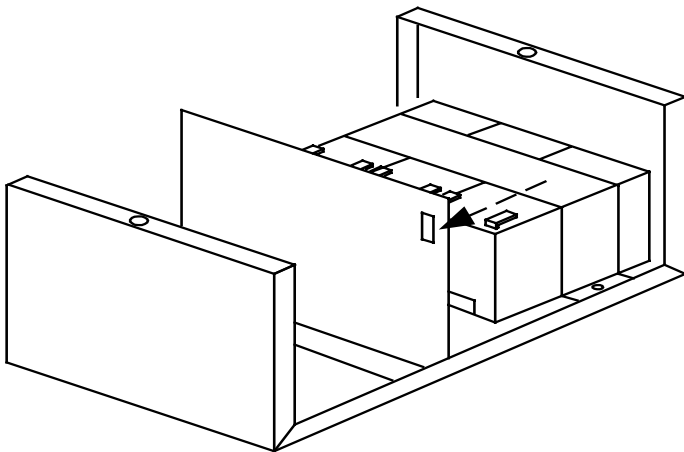

5) Insert battery connector into retaining slot in central mounting plate. The connector should be pushed through from the battery side.

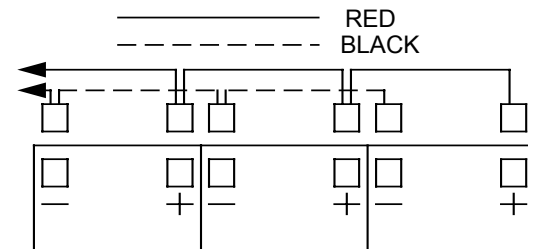

Battery Connection Detail

SUPPLY CONNECTIONS

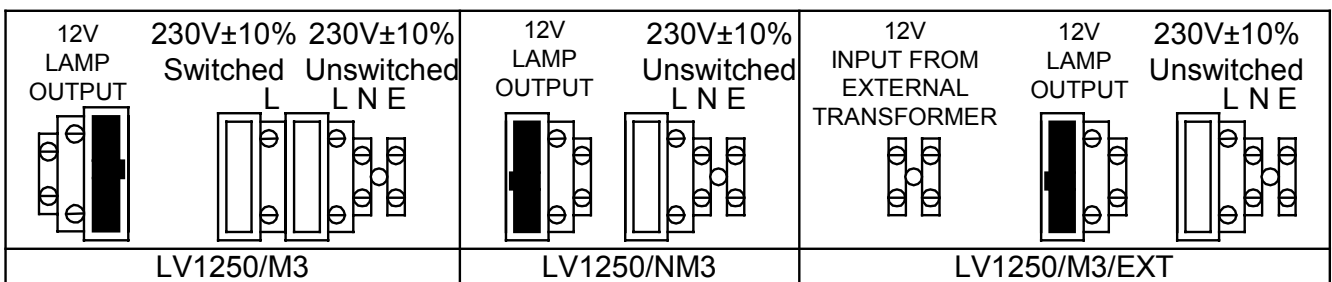

WARRANTY

All our electronic products are guaranteed for three years to cover both faulty workmanship and materials. This "Return to Base" warranty requires that the product is used within the terms and conditions stated above and in our literature, and in particular, modules must be used with the correct or approved battery pack. Items should be carefully checked thermally so that the specified temperatures are not exceeded under any conditions. Do not insulation test this product. Products returned to us under warranty must be carriage paid. Mackwell Electronics accept no liability for costs incurred. This does not affect your statutory rights.

Battery packs are guaranteed for one year, but when operating within the temperature specified in our web site have a design life in excess of four years as required by BS EN 60598-2-22.