



INSTALLATION INSTRUCTIONS

DR SERIES MICRO INTEGRATED MODULE RANGE

Module:	Reference	Cells	Rating	Duration	Lamps
	DR118	4	4 Ah	3 hours	18 watt DEL
	DR118/M1	4	1.5 Ah	1 hour	18 watt DEL
	DR126	4	4 Ah	3 hours	26 watt DEL
	DR126/M1	4	1.5 Ah	1 hour	26 watt DEL
	DR138	4	4 Ah	3 hours	38 watt 2D non-amalgam
	DR138/M1	4	1.5 Ah	1 hour	38 watt 2D non-amalgam

Battery 4 x 4Ah cells NiCd 'D' or NiMH for 3-hour duration
4 x 1.5Ah NiCd Sub C or 1.6 Ah NiMH for 1-hour duration

GENERAL DESCRIPTION

The module comprises high frequency ballast, battery charger, solid state automatic device operating a changeover relay, deep discharge protection circuit and LED charge indicator for use with rechargeable NiCd/NiMH cells in a plastic housing. The method of connection is by terminal block and a quick release mechanism is fitted so that leads may easily be removed. Wires of cross sectional area 0.5 – 1.5mm² may be connected by pushing a solid conductor into the connection or operating the release mechanism to insert a stranded conductor.

REMOTE MOUNTING OF MODULES

In general, these units are not suitable for remote mounting due to their inherent low power consumption. **MINERAL INSULATED CABLES MUST NOT BE USED IN ANY CIRCUMSTANCES.** Multicore cables, which also have an inherently high capacitance between wires may be used with caution providing the insulation is thick and opposite sides of the cable are used for opposite ends of the lamp to minimise losses.

TEMPERATURE

The ambient temperature range for the module is 0 – 55°C but in any event the centre side of can should not exceed 70°C.

BATTERIES

Mackwell supply a wide range of high quality battery packs for use with our products. They have all been designed to provide the 4 year life required by BS EN 60598-2-22 and ICEL 1001, when operated within the temperature range specified. The maximum operating temperature of Mackwell battery packs is detailed in our web site. This should not be exceeded, or the operational life of the cells will be reduced.

DEEP DISCHARGE PROTECTION

The module is fitted with a deep discharge circuit, which disconnects the battery after the cell voltage has dropped below the end of discharge level (1 volt per cell) and the circuit will remain inert until the supply is restored. This protects the battery against excessive discharge when the mains supply is removed for long periods.

FUSES

Battery	A battery fuse is incorporated in the module to protect the battery from heavy discharge
Charger	Although the charger is already short circuit protected, a fuse should always be fitted in the luminaires un-switched supply to protect the system against total failure of any unit. A suitable value is 2A anti surge
Ballast	Overload and short circuit protection is incorporated so that the ballast will safely shut down to standby mode when an abnormal load is detected in the lamp circuit. The unit will automatically reset to normal operating when the fault condition is cleared



DIMENSIONS

Dimension: 79mm x 124mm x 31mm high
Fixing centres: 108mm x 55mm
Weight: 195g

ELECTRICAL INSTALLATION

Modules comply with the EMC directive in both modes of operation, mains and emergency. Compliance will be protected by keeping lamp leads away from mains leads to avoid transfer of RFI to the live and neutral connections. Fused terminal blocks should be situated so that incoming mains connections are kept short. Product must not be insulation tested. To prevent premature lamp damage, after test the assembled luminaire should be energised for a minimum of 24 hours to fully charge the batteries. The unswitched supply should be left undisturbed during the commissioning and installation period, as otherwise lamp damage may occur.

WIRING

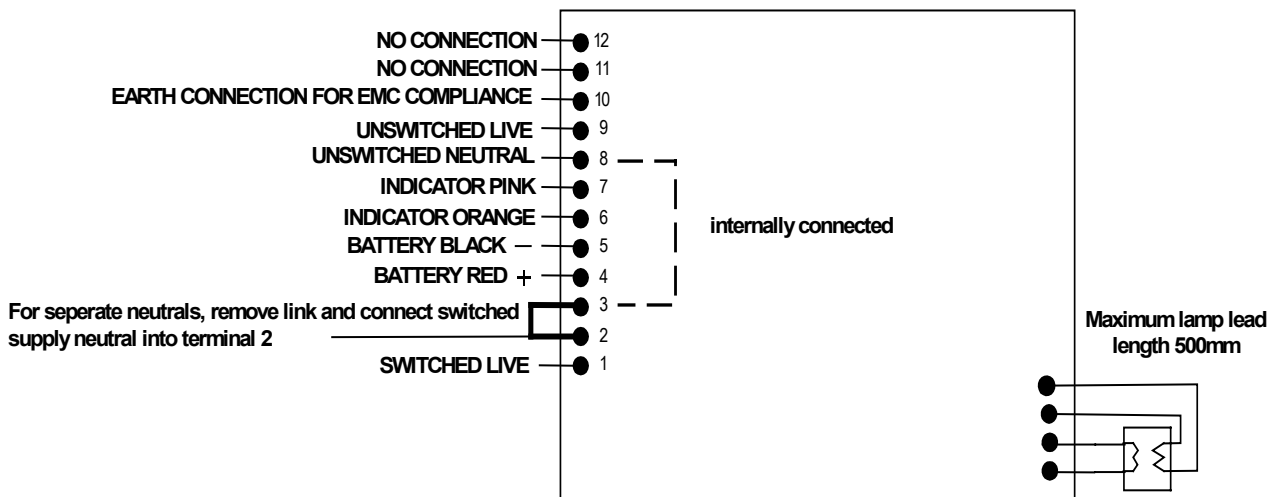

OPERATION

When the un-switched live and neutral are connected, the indicator will light to show that the battery is receiving charge and after a period of 24 hours the unit will be capable of achieving a 3 hour emergency duration. It should be noted that inserting the plug alone (connecting the battery) will not light the lamp – this will only operate when the mains has been applied and failed. Connecting the switched live will cause the ballast to operate the lamp in mains mode and this can be switched in the usual way

WARRANTY

All our electronic products are guaranteed for three years to cover both faulty workmanship and materials. This “Return to Base” warranty requires that the product is used within the terms and conditions stated above and in our literature, and in particular, modules must be used with the correct or approved battery pack. Items should be carefully checked thermally so that the specified temperatures are not exceeded under any conditions. Do not insulation test this product. Products returned to us under warranty must be carriage paid. Mackwell Electronics accept no liability for costs incurred. This does not affect your statutory rights.

Battery packs are guaranteed for one year, but when operating within the temperature specified in our web site have a design life in excess of four years as required by BS EN 60598-2-22.